



## Features

- Native XGA (1024 x 768) Resolution
- 3,000 ANSI Lumens, 10,000:1 High Contrast Ratio
- SmartEco™ Power Saving Technology
- Up to 7,000 Hours Lamp Life
- PointWrite Interactive Kit Compatible
- Wall Mount Included
- Full 3D Ready



PointWrite Kit (PW01U)



Touch Module (PT01)



## Input and Output Terminals



- 1 Computer in 1 & 2 (D-sub 15pin)
- 2 Monitor Out (D-sub 15pin)
- 3 S-Video In (Mini DIN 4pin)
- 4 Composite Video in (RCA)
- 5 HDMI
- 6 LAN
- 7 USB (Type Mini B)
- 8 PointWrite
- 9 RS232 (DB-9pin)
- 10 Audio In/Out (Mini Jack)
- 11 Audio (L/R)

## Specifications

Projection System	DLP®																													
Native Resolution	XGA (1024x768)																													
Brightness	3,000AL																													
Contrast Ratio	10,000:1																													
Display Color	1.07 Billion Colors																													
Lens	F2.5, f=5.1mm																													
Aspect Ratio	Native 4:3 (5 aspect ratio selectable)																													
Throw Ratio	0.43																													
Image Size (Diagonal)	68"~85", Optimal 78"																													
Zoom Ratio	Fix																													
Lamp Type	230W																													
Lamp (Normal/Economic Mode)*	4000/5000/7000 hours																													
Keystone Adjustment	1D, Vertical +/- 40 degrees																													
Projection Offset	140% ±5%																													
Resolution Support	VGA(640 x 480) to UXGA(1600 x 1200)																													
Horizontal Frequency	15~102KHz																													
Vertical Scan Rate	23~120Hz																													
Compatibility	HDTV Compatibility: 480i, 480p, 576i, 576p, 720p, 1080i, 1080p Video Compatibility: NTSC, PAL, SECAM,																													
Interface	<table border="0"> <tr> <td>Computer in (D-sub 15pin)</td> <td>x 2(Shared with component)</td> </tr> <tr> <td>Monitor out (D-sub 15pin)</td> <td>x 1</td> </tr> <tr> <td>Composite Video in (RCA)</td> <td>x 1</td> </tr> <tr> <td>S-Video in (Mini DIN 4pin)</td> <td>x 1</td> </tr> <tr> <td>HDMI</td> <td>x 1</td> </tr> <tr> <td>Audio in (Mini Jack)</td> <td>x 1</td> </tr> <tr> <td>Audio out (Mini Jack)</td> <td>x 1</td> </tr> <tr> <td>Audio L/R</td> <td>x 1</td> </tr> <tr> <td>Speaker</td> <td>10W x 2</td> </tr> <tr> <td>USB (Type mini B)</td> <td>x 2 (PointWrite interactive module)</td> </tr> <tr> <td>USB (Type B)</td> <td>x 1 (FW download)</td> </tr> <tr> <td>RJ45</td> <td>x 1 (LAN control)</td> </tr> <tr> <td>RS232 (DB-9pin)</td> <td>x 1</td> </tr> <tr> <td>IR Receiver</td> <td>x 2 (Front)</td> </tr> </table>		Computer in (D-sub 15pin)	x 2(Shared with component)	Monitor out (D-sub 15pin)	x 1	Composite Video in (RCA)	x 1	S-Video in (Mini DIN 4pin)	x 1	HDMI	x 1	Audio in (Mini Jack)	x 1	Audio out (Mini Jack)	x 1	Audio L/R	x 1	Speaker	10W x 2	USB (Type mini B)	x 2 (PointWrite interactive module)	USB (Type B)	x 1 (FW download)	RJ45	x 1 (LAN control)	RS232 (DB-9pin)	x 1	IR Receiver	x 2 (Front)
Computer in (D-sub 15pin)	x 2(Shared with component)																													
Monitor out (D-sub 15pin)	x 1																													
Composite Video in (RCA)	x 1																													
S-Video in (Mini DIN 4pin)	x 1																													
HDMI	x 1																													
Audio in (Mini Jack)	x 1																													
Audio out (Mini Jack)	x 1																													
Audio L/R	x 1																													
Speaker	10W x 2																													
USB (Type mini B)	x 2 (PointWrite interactive module)																													
USB (Type B)	x 1 (FW download)																													
RJ45	x 1 (LAN control)																													
RS232 (DB-9pin)	x 1																													
IR Receiver	x 2 (Front)																													
Dimensions (WxHxD)	287.5 x 373.3 x 185.9 mm (w/o Mirror) 287.5 x 373.3 x 201 mm(w Mirror)																													
Weight	5KG(w/o wall mount)																													
Power Supply	AC100 to 240 V, 50 to 60 Hz																													
Power Consumption	typical 290W, standby power <0.5W																													
Audible Noise	33/29 dBA (Normal/Economic mode)																													
Languages	Arabic/Bulgarian/ Croatian/ Czech/ Danish/ Dutch/ English/ Finnish/ French/ German/ Greek/ Hindi/ Hungarian/ Italian/ Indonesian/ Japanese/ Korean/ Norwegian/ Polish/ Portuguese/ Romanian/ Russian/ Simplified Chinese/Spanish/ Swedish/ Turkish/ Thai/ Traditional Chinese (28 Languages)																													
Picture Mode	Dynamic/Presentation/sRGB/Cinema/(3D)/User 1/User 2																													
Accessories (Standard)	Remote Control w/ Battery, Power Cord, User Manual CD Quick Start Guide, Warranty Card, VGA(D-sub 15pin) Cable Dust filter(C SKU), Wall mount installation guide																													
Accessories (Optional)	<table border="0"> <tr> <td>Spare Lamp Kit</td> <td>P/N: 5J.J8M05.011</td> </tr> <tr> <td>3D Glasses (DGD24)</td> <td>P/N: 5J.J7L25.002</td> </tr> <tr> <td>PointWrite Kit (PW01U)</td> <td>P/N: 5J.J8L26.20E</td> </tr> <tr> <td>PointWrite Pen Only</td> <td>P/N: 5J.J9A26.001</td> </tr> <tr> <td>Touch Module</td> <td>P/N: 5J.J8L26.10E</td> </tr> </table>		Spare Lamp Kit	P/N: 5J.J8M05.011	3D Glasses (DGD24)	P/N: 5J.J7L25.002	PointWrite Kit (PW01U)	P/N: 5J.J8L26.20E	PointWrite Pen Only	P/N: 5J.J9A26.001	Touch Module	P/N: 5J.J8L26.10E																		
Spare Lamp Kit	P/N: 5J.J8M05.011																													
3D Glasses (DGD24)	P/N: 5J.J7L25.002																													
PointWrite Kit (PW01U)	P/N: 5J.J8L26.20E																													
PointWrite Pen Only	P/N: 5J.J9A26.001																													
Touch Module	P/N: 5J.J8L26.10E																													
UPC / Part #	8400460-3027-8 / 9H.J8M77.23A																													
Limited Warranty	3 Years Parts/Labor; 1 Year or 2,000 hours of lamp life																													

\*Lamp life results will vary depending on environmental conditions and usage. Actual product's features and specifications are subject to change without notice.



MX852UST 08-28-14-BQca



BenQ Canada Corp.  
Tel: (416) 363-2367 www.BenQ.ca

BenQ is a registered trademark of BenQ Corp. DLP is a registered trademark of Texas Instruments. All rights reserved. Product names, logos, brands, and other trademarks featured or referred to in this materials are the property of their respective trademark holders. Specifications subject to change without notice.



Because it matters

# MX852UST Digital Projector

## Distance Chart

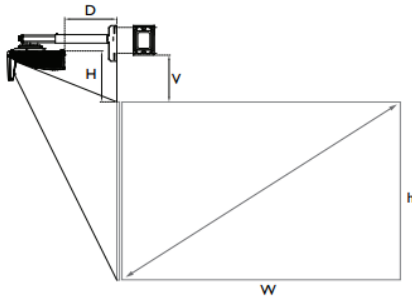

XGA											
Screen size (Diagonal)		Screen size Width (W)		Screen size Height (h)		Projection distance (D)		Offset (H)		Scale parameter	Distance between Wall plate & projection screen (V)
inch	mm	inch	mm	inch	mm	inch	mm	inch	mm	inch	
68	1727	54	1382	40	1036	11.16	283.4	11.86	301.3	500	273.5
70	1778	55	1422	42	1067	11.91	302.4	12.15	308.5	515	280.7
75	1905	59	1524	45	1143	13.83	351.4	12.88	327.2	560	299.4
77	1956	61	1565	46	1173	14.62	371.4	13.18	334.8	585	307
80	2032	63	1626	48	1219	15.72	399.4	13.60	345.4	615	317.6
82	2083	65	1666	49	1250	16.51	419.4	13.90	353	635	325.2
85	2159	67	1727	51	1295	17.61	447.4	14.32	363.7	665	335.9

## Ceiling Mount Chart

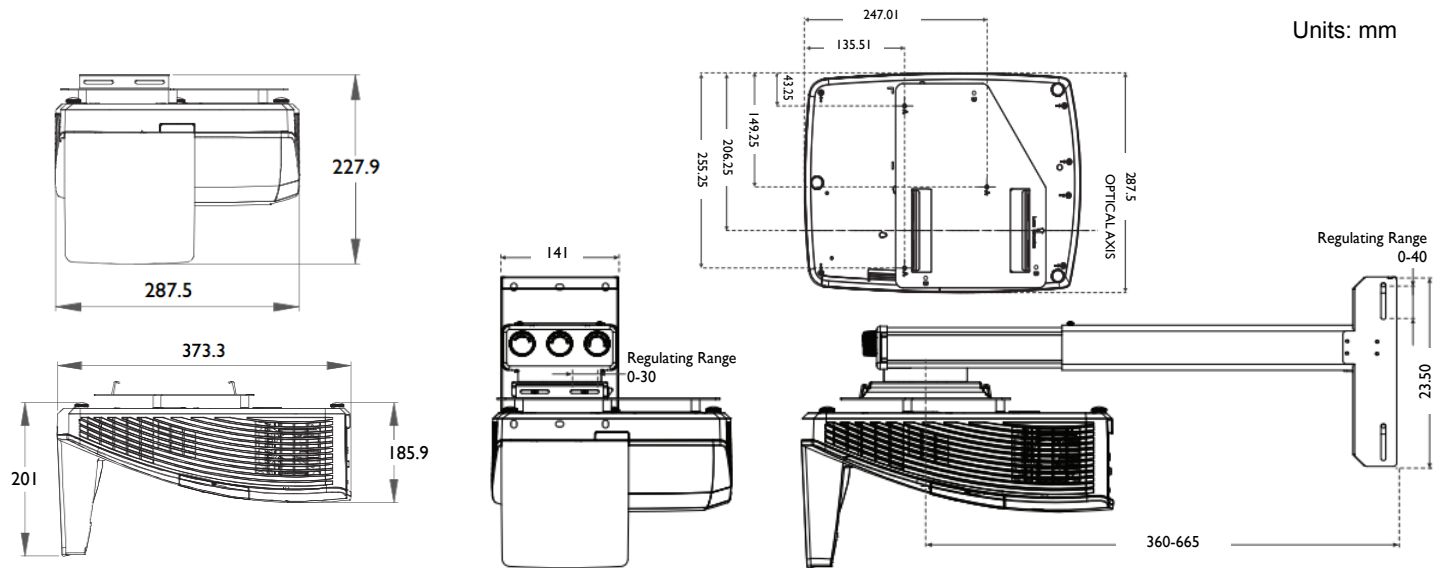

## Dimensions



Because it matters